

A Assembly Instructions

Tower Carousel

Art-No. 20.01.150



Revision history

Revision 0 – 2004-04-08

First approved version

Assembly instructions

Revision 6 – 2011-09-06

Nur noch 4 Befestigungsschrauben

VA-Rohr FH

All rights reserved.

© Copyright 2003 Spogg Sport-Güter GmbH

Contents

A	Assembly Instructions	1
1	Introduction Assembly	1
2	Datasheet	3
3	Delivery Contents (parts list with part numbers)	5
4	Erection Instructions	8
5	Post Installation Checks	18
B	Maintenance Instructions	19
6	Introduction Maintenance	22
7	General Maintenance Information	23
8	Specific Maintenance Advice	24
9	Maintenance Timetable	25
10	Monthly Maintenance	27
11	Quarterly Maintenance	27
12	Annual Maintenance	28
13	Maintenance Printout	29
14	Hand Over Document	31

List of Tables

Table 3-1: Delivery Contents, in words	5
Table 3-2: Delivery Contents, in symbols	6

1 Introduction Assembly

1.1 General Information

This equipment should be installed, inspected, maintained and operated in accordance with EN1176-7 guidelines.

Before installation work commences, please check that you have all of the equipment and fixation components in the parts list provided (see Tables 3-1 and 3-2).

Please consider that the installation has to be carried out only on even terrain (max.slope up to 3%).

Any spare parts that may be required can be obtained directly from your supplier.

Please do not hesitate to call your supplier if you have any problems during installation or with any other questions.



Attention

Following installation, complete assembly instructions, maintenance instructions and a maintenance record must be sent to the operator who must confirm receipt in writing. See the last page of this document.



Attention

All nuts and bolts are hot-dip galvanised or stainless steel. One of the characteristics of stainless steel is that uncontrolled cold welding may occur when the nuts are tightened. To prevent this, it is necessary to spray the nuts and bolts with Teflon spray or another similar lubricant.

We hereby confirm that this play equipment has been tested and certified in accordance with the play equipment standard EN 1176.

Drawings / Views

All optical drawings are showing only the measurements/dimensions and are no mandatory technical views of the complete item.

We reserve the right to change technical details of our articles which are serving for the further development of our articles and are reasonable for the customer.

Measurement / Tolerances

Because of the properties and characteristics of the components, minor measurement tolerances compared to the indication on the sketches are possible.

This concerns all shown measurements except the foundation measurements resp. measurements below upper edge ground level/play area.

2 Datasheet

1. Space requirement: Ø 2.00 m
Urgent recommended safety zone Ø 11.00 m
Lawful required safety zone: Ø 8.00 m
Height of fall 2.80 m

The images (individual drawings) are not to scale!!



Attention!

According to EN 1176-5 (paragraph 5.3) the statutory fall protection area has to be an additional 2m diameter in relation to the space requirement.

We strictly recommend keeping our specified, increased safety area although it is sufficient to place fall protection material onto the statutory safety area.

**Never limit the transition to e.g. lawn or similar material with solid or hard bordering!
No solid objects (e.g. benches, bollards, dustbins, fences etc.) are to be installed within the specified, increased safety area!**

2. Required Safety Surface:

Surface material	Description mm	Minimum thickness of layer mm	Maximum height of fall mm
Topsoil grass			<= 1000*
Chipped bark	20 – 80 grain size	400	<= 3000
Wood chippings	5 – 30 grain size	400	<= 3000
Sand	0.2 – 2 grain size	400	<= 3000
Gravel	2 – 8 grain size	400	<= 3000
Other ground materials	As recommended by manufacturer	400	

3. Name and overall dimension of the largest component:
Steel post (1 item) length 5.00m, Ø 193 mm
4. Name and weight of the heaviest component:
Steel post (1 item), 127 kg
5. Intended age group: 5 years and over
6. **Please note that this equipment is set in concrete.**
Concrete: C20/25 (B25)
Foundations/area to be excavated:

1 x 1.20 m long x 1.20 m wide, total depth 1.10 m including 10 cm drainage
1 x 1.20 m long x 1.20 m wide x 0.80 deep



Achtung

Round off foundation edges (min.R = 100 mm)! Sizes of foundations are designed for soils class "4-5" (natural ground).

Soil class 4: soft to medium plasticity, interleave bound, with minor portion of stone (portion < 30% with bigger diameter of 63 mm grain size)

Soil class 5 : ground with soil class 3 and 4 with big portion of stones (portion > 30% with bigger diameter of 63 mm grain size)

In case of sandy and soft soils, the surface measure of foundations have to be enlarged for about 50%!

7. Top edge of concrete rounded.
8. Assembly time, once foundations complete: 2 – 3 hours.
Required assistance: 2 – 3 people.
9. Any spare parts which may be required can be obtained directly from your supplier
10. **We hereby confirm that this item of play equipment has been tested and certified in accordance with the play equipment standard EN 1176.**

3 Delivery Contents (parts list with part numbers)













3.1 In Words







Table 3-1: Delivery Contents, in words

Pos.	Quantity	Element/Description	Size	O.K.	Missing
1	1	Steel post	Ø 193 mm, 5.00 m long		
2	1	Netting, Ø 2.00 m (preassembled)	Ø 2.00 m		
3	2	Protective clamping rings	Ø 193 mm		
4	1	Handwheel (optional)	Ø 193 mm, 140 mm long		
5	1	Rotation element			
6	1	Aluminium cover (blank)			
100	8	Allen screws	M10 x 25, VA		
101	8	Tooth lock washers	M10, VA		
102	1	Threaded rod	M16 x 165 mm long, galv.		
103	1	Hexagon nut, DIN 934	M16, VA		
104	1	Washer with large external diameter, DIN 9021	Ø 17 mm, VA		
105	1	Stop nut, DIN 985	M16, VA		
106	1	Cap, black	For M16		
107	20	Self-tapping PIAS screws	M6.3 x 45, VA		
108	2	Loctite			
109	3	Cover ring	black		
110	2	Steel pipe	Ø 199 mm , 500 mm lg., 2 mm, VA		
111	16	Self-cutting screw	5,5 x 25 mm long		
112	2	Cover ring	black		
	1	Concrete slab	By the customer		

3.2 In Symbols

Table 3-2: Delivery Contents, in symbols

Pos.	Quantity	Symbol
1	1	 Ø 193 mm - 5,00 m lang
2	1	 Ø 2 m
4	1	 OPTION (Ø 193 mm, 140 mm lang)
5	1	
6	1	
100	8	 M10 x25, VA
101	8	 M10, VA
102	1	 M16 x 165 mm lang, verz.
103	1	 M16, VA
104	1	 Ø 17 mm, VA
105	1	 M16, VA
106	1	 f. M16
107	20	 6,3 x 45, VA

Pos.	Quantity	Symbol
108	2	
109	3	
110	2	 outside-Ø 199 mm , length = 500 mm, 2 mm thick
111	16	 M5,5 x 25, VA
112	2	
	1	 Concrete Slab – Supplied by Customer

4 Erection Instructions

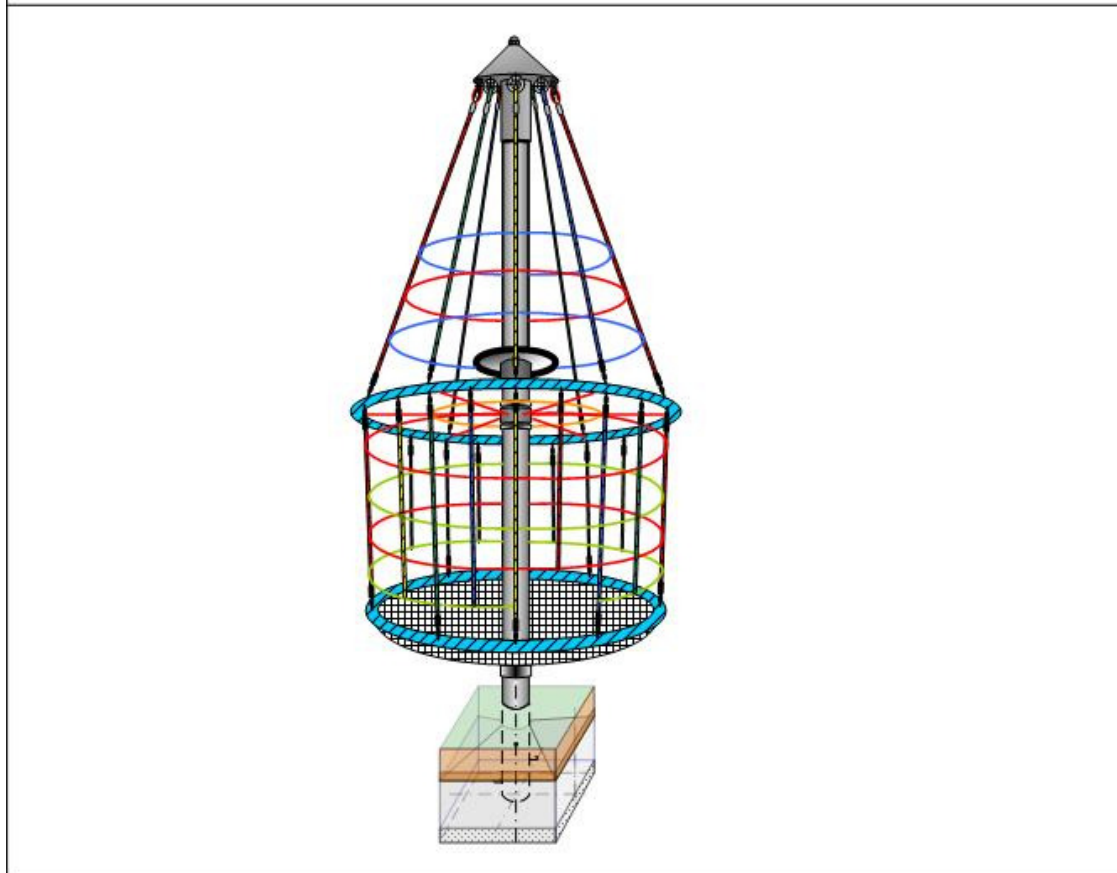
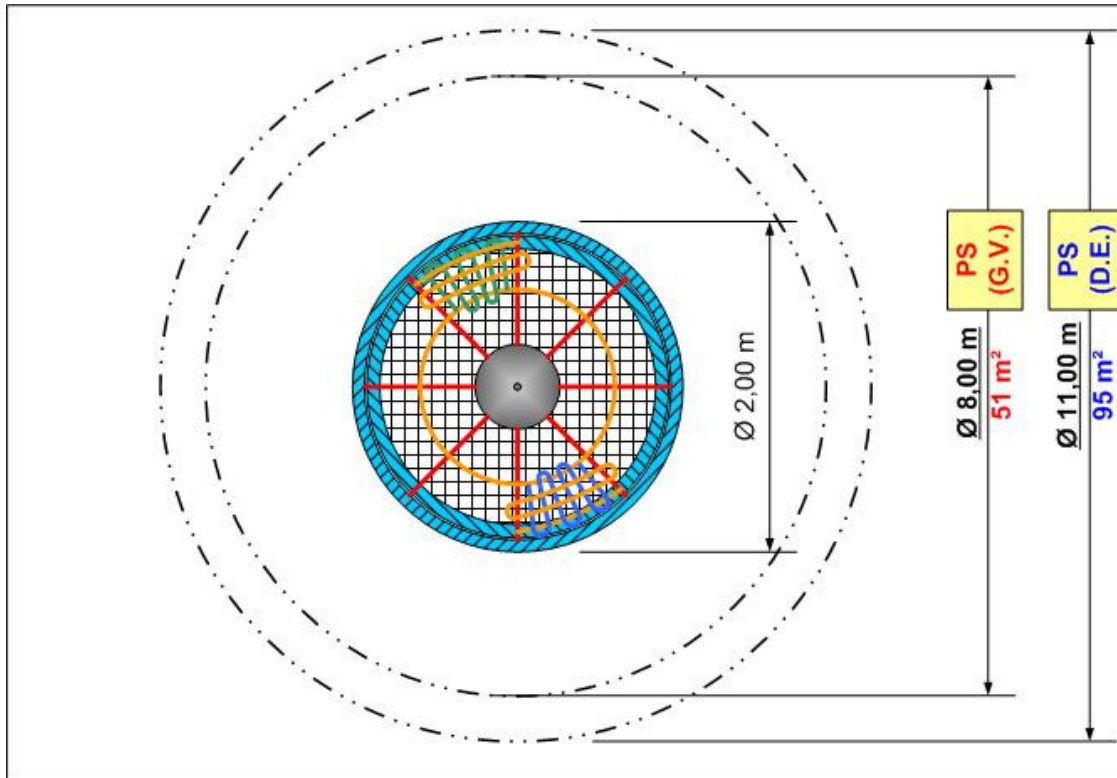

M:\Spogg\Deutsch\2001150 Turmkreisel\aktuelle Montageanleitung\dot\Bilder\BL 1\Sicherheitsbereich .vsd Donnerstag, 13. November 2008

Screw locking device !

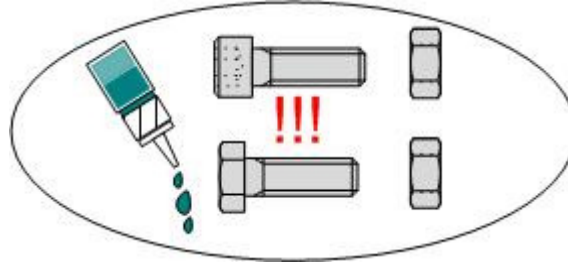

**Glue all screws, nuts and sleeves with loctite.
(not less than 5 drops !)
(except for lock nut)**

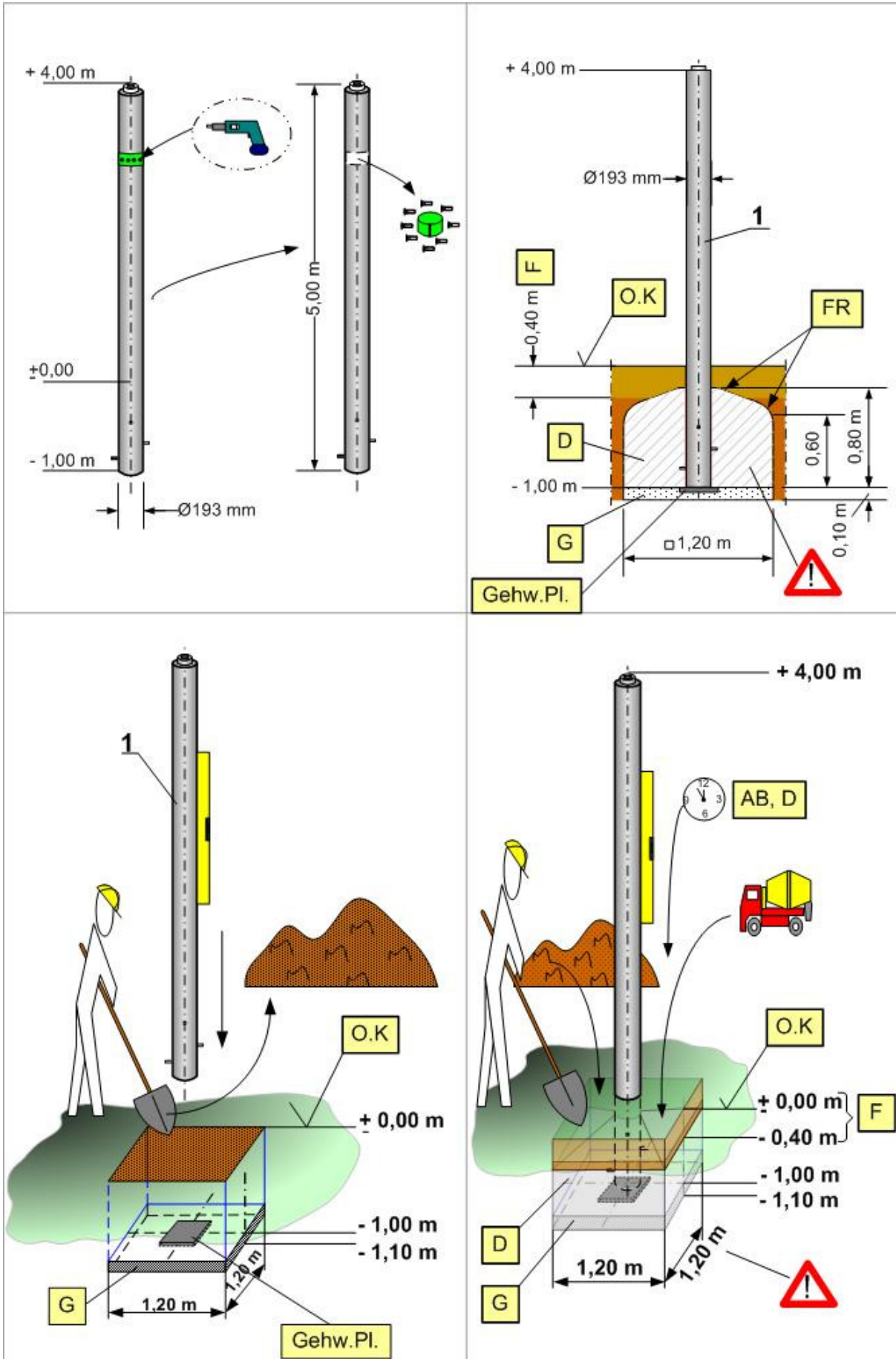

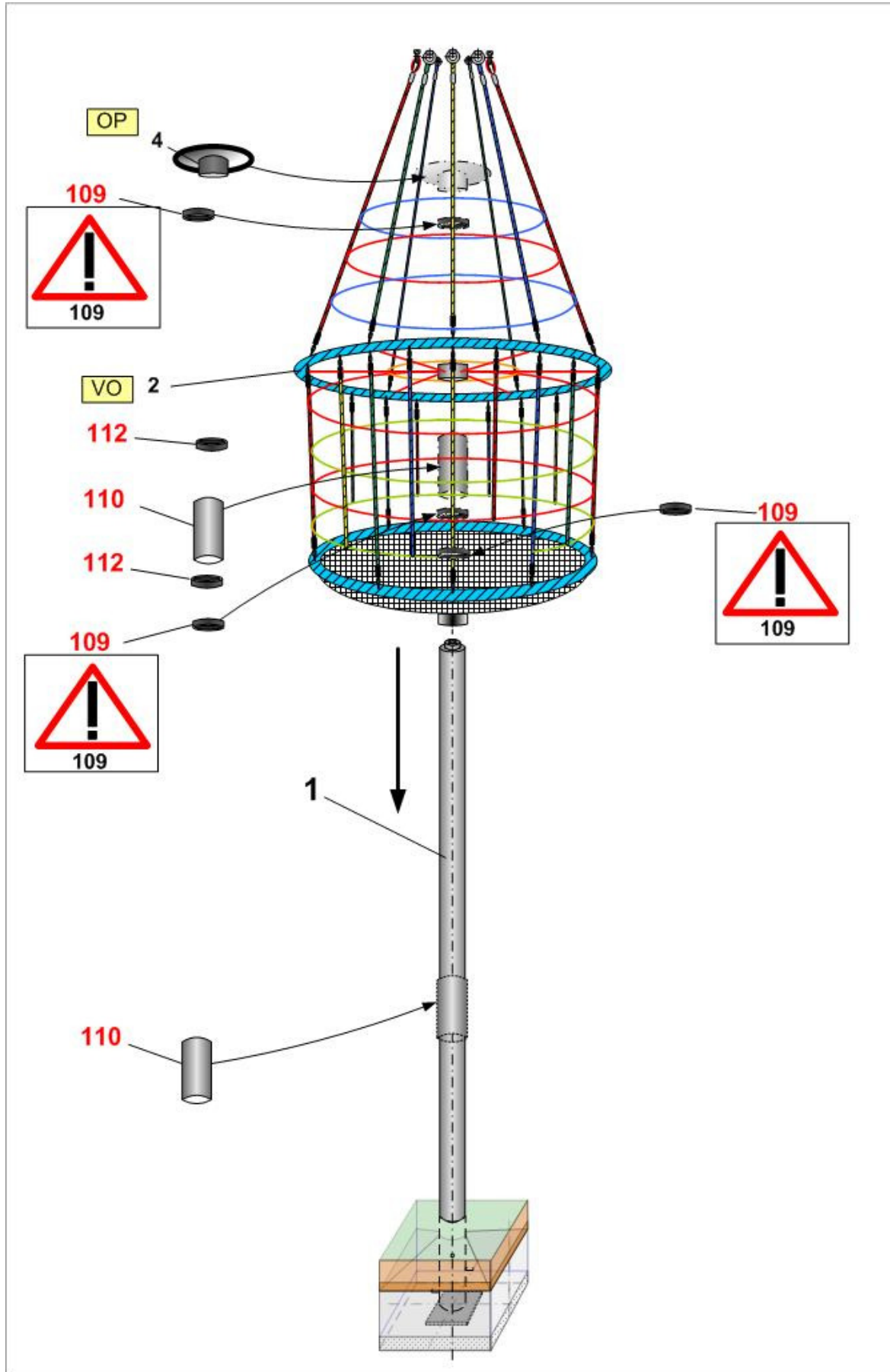

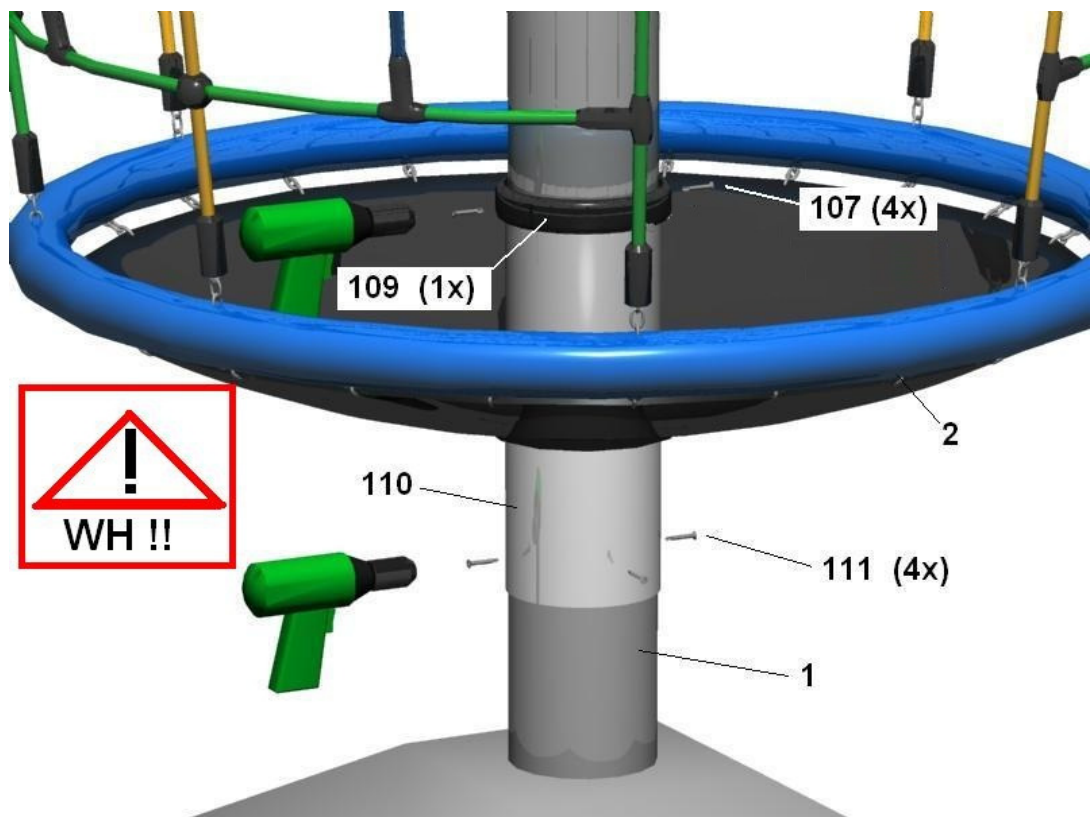
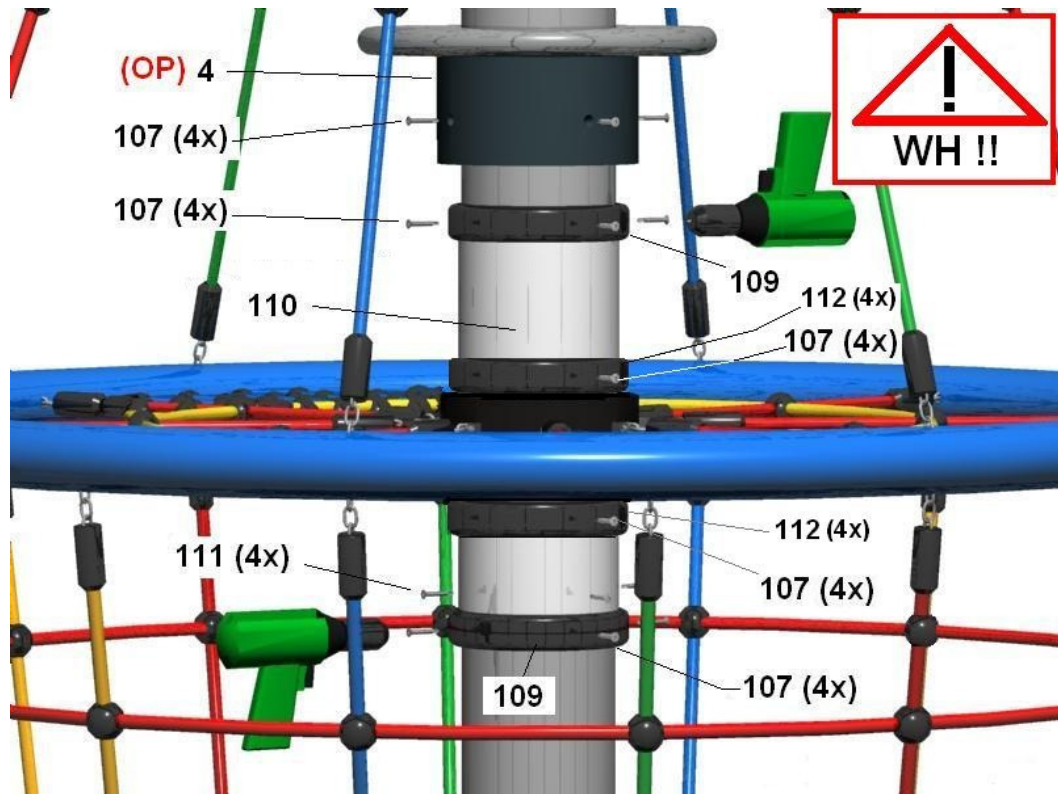

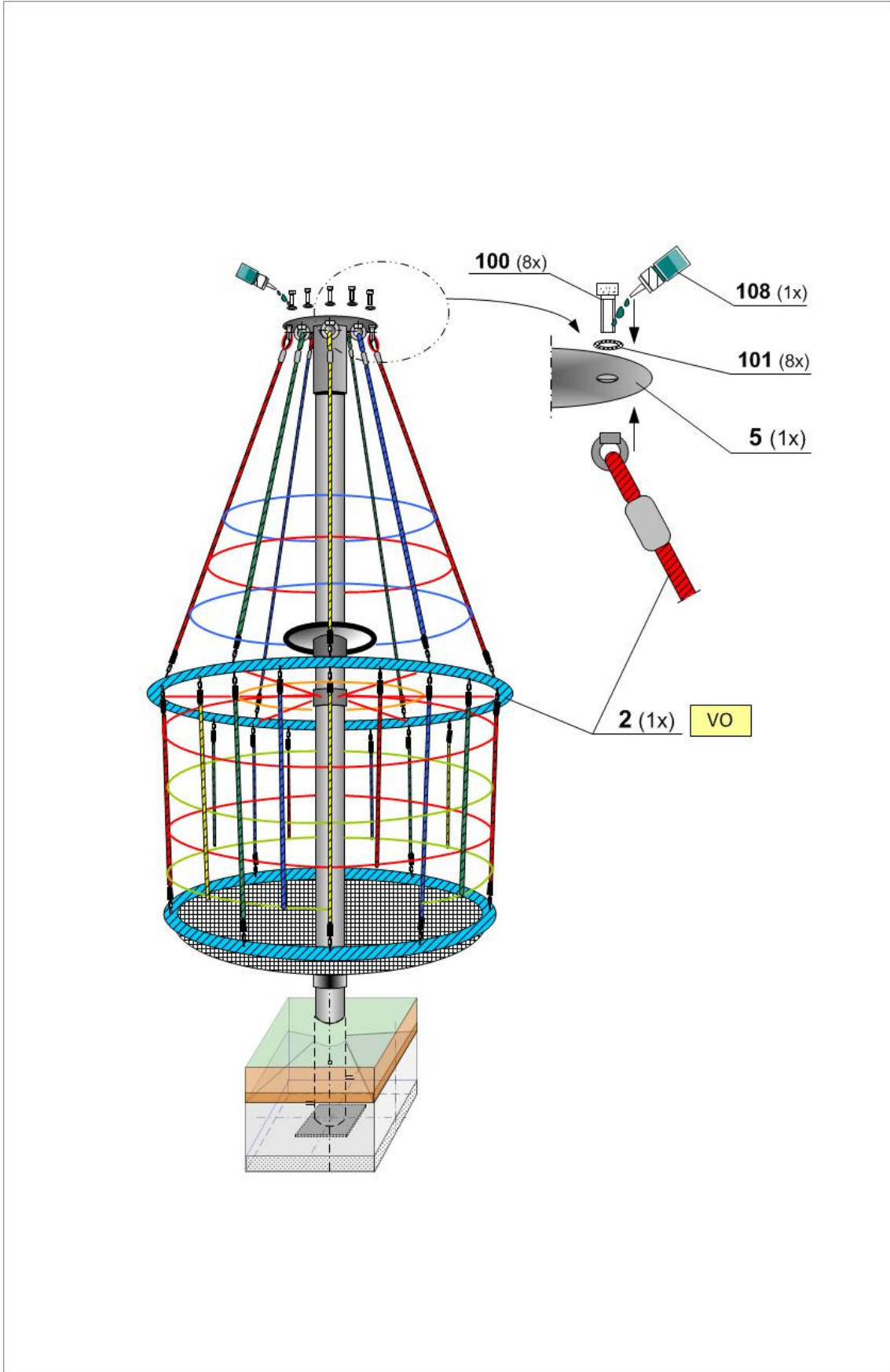

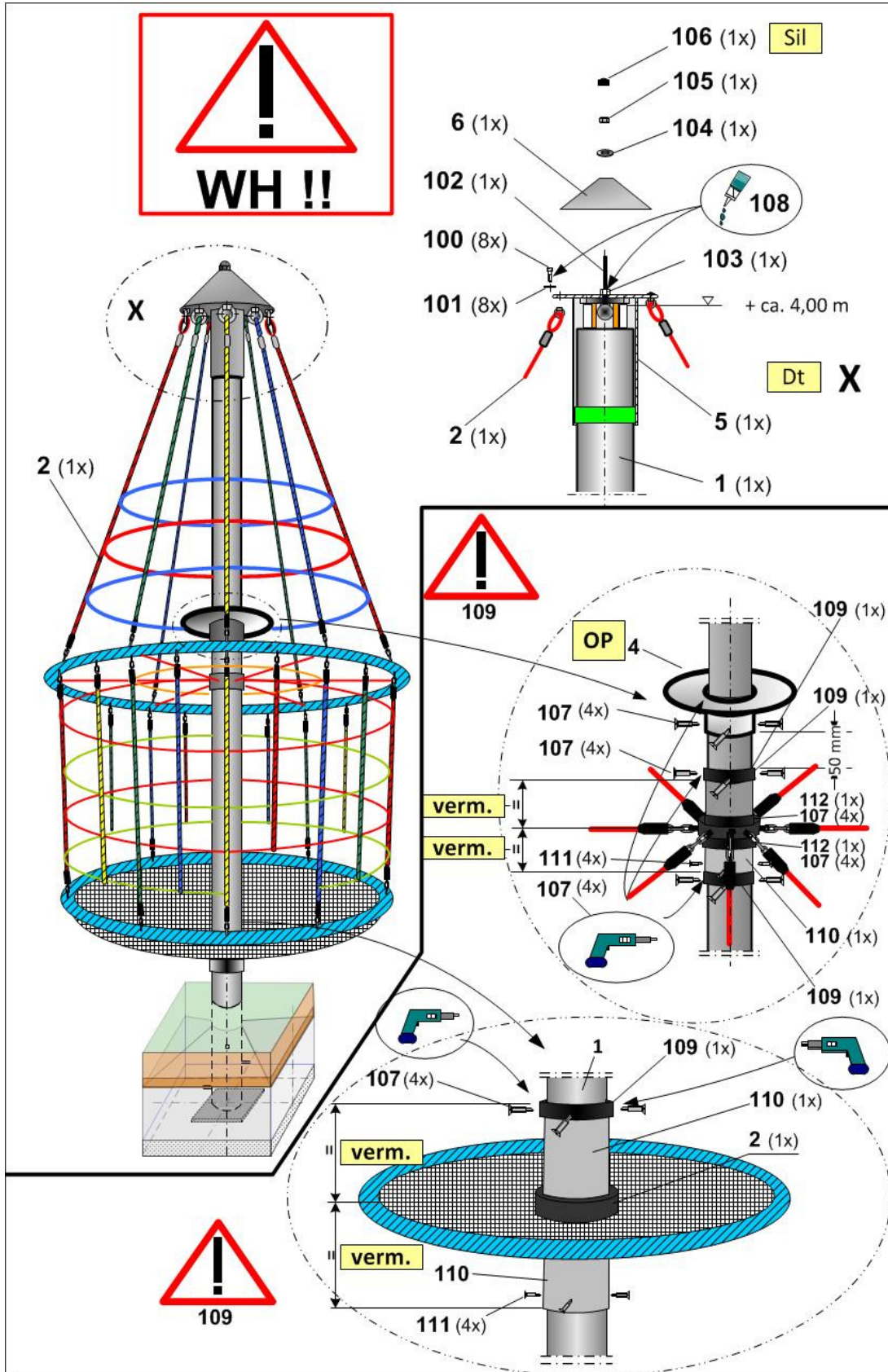

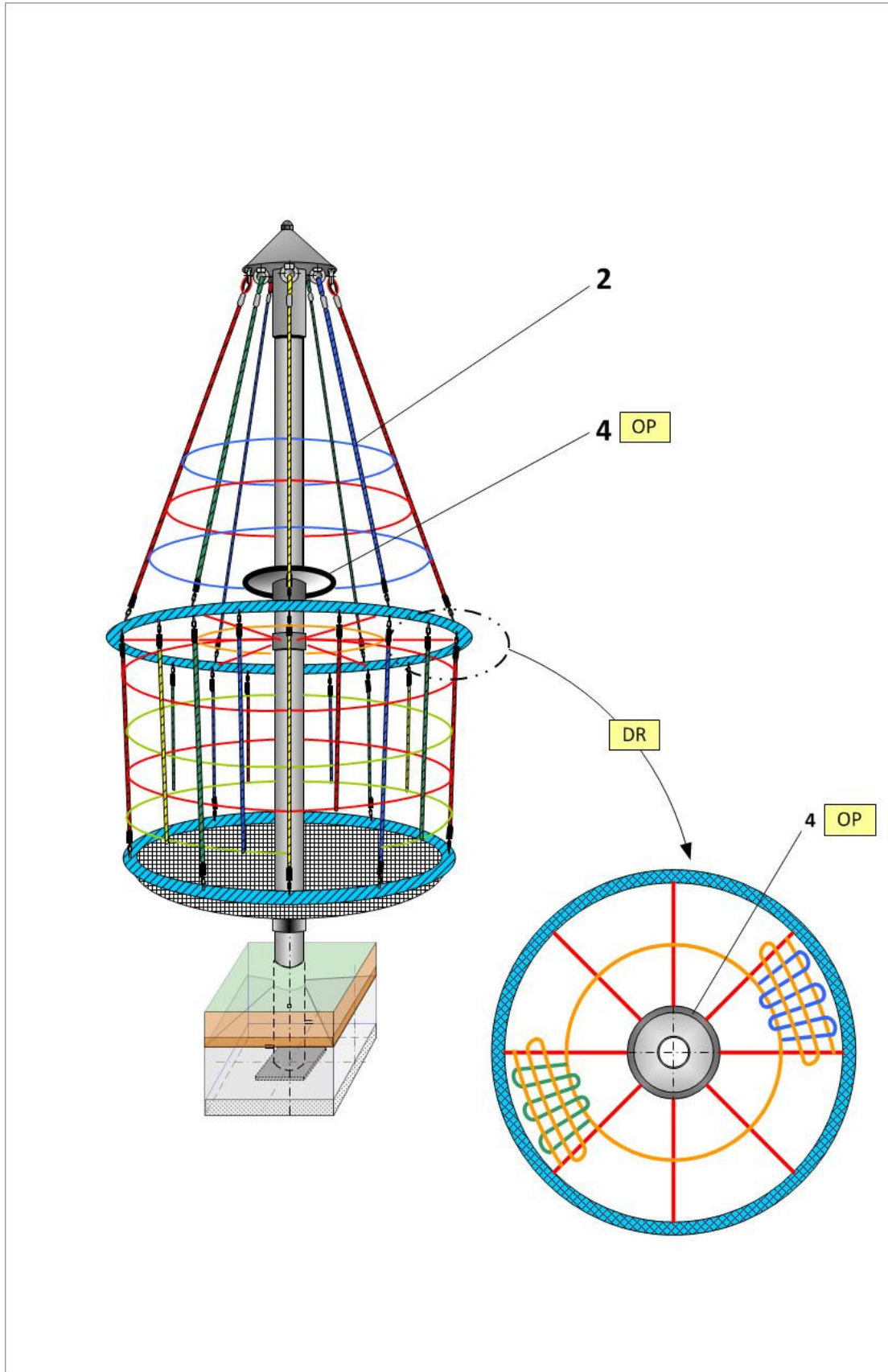





AB	Setting time of at least 4-5 days
D	B25 concrete (for foundations)
Dt	Detail
DR	Aerial view
F	Fall protection
verm.	Align iron pipe-covering (Pos. 110) and fix it with screws (Pos. 111) and rings (Pos. 107) on center pole.
FR !!	Radius of foundations at least 10 cm
Gehw.PI.	Plate (e.g. footpath/concrete plate - has to be installed by customer on construction site)
G	Drainage layer (10 cm thick)
O.K	Upper edge of playing level
OP	Optional (not standard)
PS (D.E.)	urgent recommended safety zone: Ø 11.00 m / 95 m ²
PS (G.V.)	lawful required safety zone: Ø 8.00 m / 51m ²
 109	<u>Attention!</u> <u>Consider mounting direction (see cut-off at the inside) of the PA-rings (Pos. 109)</u>
	Round off foundation edges (min.R = 100 mm)! Sizes of foundations are designed for soils class“4-5” (natural ground). Soil class 4: soft to medium plasticity, interleave bound, with minor portion of stone (portion < 30% with bigger diameter of 63 mm grain size) Soil class 5 : ground with soil class 3 and 4 with big portion of stones (portion > 30% with bigger diameter of 63 mm grain size) In case of sandy and soft soils, the surface measure of foundations have to be enlarged for about 50%!
 WH !!	<u>Important!!</u> The final fixation off the iron pipe-covering (Pos.110) and the rings (Pos. 109) with self-cutting-screws (Pos. 107 und 111) can be carried out after installation of netting (Pos.2) at the pole (see Dt. X)
VO	Preassembled

See drawings

5 Post Installation Checks



Notice

If the equipment has not been installed safely, you must ensure that the public is prevented from using it.

5.1 Marking filler depth

- Labelling the posts to show the depth of material provided as fall protection (i.e. loose filler).

5.2 The equipment has not been installed safely in the following cases:

- Safe equipment installation is not complete.
- The protective surface has not been installed yet.
- Appropriate maintenance work cannot guarantee operational safety.

5.3 Removal of all assembly aids

- Please make sure that all assembly aids have been removed from the playing area. The equipment must not be approved for use until this check has been made.

5.4 Information about inspection of the equipment before it is used for the first time

- There are no special inspection requirements to be met before the equipment is used for the first time.

5.5 Retighten bolts

- After one week of play, please retighten all bolts again. Later upon respective maintenance.

B Maintenance Instructions

Tower Carousel Art-No. 20.01.150



Revision history

Revision 0 – 2004-04-08

First approved version

Maintenance instructions

Revision 6 – 2011-06-09

Nur noch 4 Befestigungsschrauben

VA-Röhr FH

All rights reserved.

© Copyright 2003 Spogg Sport-Güter GmbH

6 Introduction Maintenance

6.1 General Information

This equipment should be installed, inspected, maintained and operated in accordance with EN 1176-7 guidelines.



Please note: Providing any necessary repairs are carried out, a piece of play equipment that is inspected regularly cannot become so damaged that it is dangerous.

Any spare parts which may be required can be obtained directly from your supplier.



This equipment should only be assembled, maintained and repaired by **persons with the necessary expertise**.
A copy of the inspection record should be given to the operator, who must confirm receipt.

**This maintenance instruction is based on the standard
“EN 1176-1:2008”.**

7 General Maintenance Information

7.1 Maintenance intervals

Maintenance intervals are based on average use. Please note that more frequent inspections and/or maintenance are required if the play equipment is subject to intensive use.

7.2 Inspection frequency

The frequency of inspections must be based on actual use. Factors that affect frequency include vandalism, location (e.g. coastal proximity), air pollution and the age of the equipment.

7.3 Maintenance products and procedures

All nuts and bolts are hot-dip galvanised or stainless steel. One of the characteristics of stainless steel is that uncontrolled cold welding may occur when the nuts are tightened. To prevent this, it is necessary to spray the nuts and bolts with Teflon spray or another similar lubricant.

7.4 Spare parts

All spare parts must conform to the manufacturer's specifications.

7.5 Identifying spare parts

All spare parts are listed in the parts list. The parts list follows the installation requirements.

7.6 Special instructions for the disposal of individual equipment components

No special instructions are necessary for the disposal of individual equipment components.

7.7 Special measures during the break-in period

No later than 2 weeks after assembly, all screwed connections should be checked and tightened if necessary.

7.8 Maintenance of protective surfaces

Surfaces providing fall protection must also be maintained regularly. It is particularly important to maintain the correct level of loose surface material and add more if necessary.

7.9 Faults



Attention

Faults must be repaired as soon as they are detected. If serious defects that compromise safety cannot be repaired straight away, the public must be prevented from using the equipment with immediate effect.

7.10 Loose screws



Attention

Loose screws always cause quality problems and put safety at risk. Therefore, loose screws should always be tightened and checks carried out to ensure that there are no missing screws (e.g. look out for holes you can see through).

7.11 Preventing equipment use

Use of the equipment should be prevented in the event of incomplete installation, disassembly, maintenance, repairs and faults.

7.12 Safeguarding the guarantee

Steel posts and footings are guaranteed if regular maintenance is carried out and recorded in writing. Maintenance first takes place after 3 years. The steel posts must be excavated as far as the concrete foundations and checked for corrosion. Zinc paint should be applied to any corroded areas and scratches.

8 Maintenance Timetable

8.1 Special Advices

8.1.1 Maintenance interval

We strongly advise you to carry out inspections and maintenance work within the specified periods as use of the equipment, the weather and malicious vandalism cause wear and tear that compromises the safety and function of the equipment.

8.1.2 Maintenance intervals in the event of intensive use

Please note that more frequent inspections and/or maintenance are required if the play equipment is subject to intensive use.

8.1.3 Faults that compromise safety



In the event of a fault that compromises safety, quick action must be taken. This may involve repairing it immediately or shutting down and dismantling the equipment.

8.1.4 Faults that compromise function



Faults that compromise function should also be repaired immediately. Such faults lower the value of the equipment to the user and encourage malicious vandalism, which may render the equipment less safe. Any damage should also be repaired immediately.

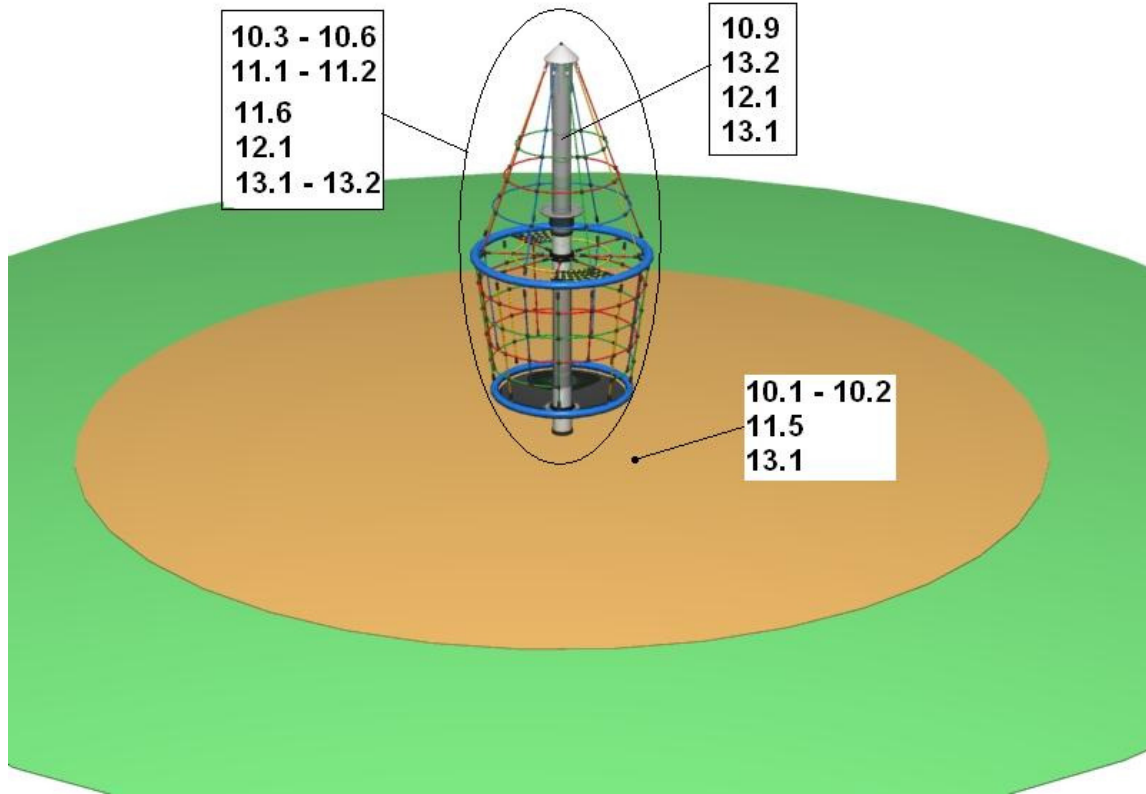

9 Monthly Maintenance

- 9.1 Check the spaces between the equipment and the ground (clearance and height of fall).
- 9.2 Check the ground surface in the area with fall protection for hard objects and loose foundations.
- 9.3 Check all connecting elements and fittings for wear and tear and tighten if necessary. Replace damaged or missing parts.
- 9.4 Check that moving metal parts (joints, springs, etc.) move smoothly and are not worn. Replace if necessary. It is not necessary to lubricate joints as we only use maintenance-free metal roller bearings.
- 9.5 Check all attachments such as chains, ropes, nets, etc. for damage and replace if necessary.
- 9.6 Check rubber parts, sleeves, etc. for wear and tear or damage and replace if necessary.
- 9.7 If necessary, remove excess padding material from the post footings due to danger of rotting.
- 9.8 Check the surface of wooden parts for damage caused by the weather or external influences and mould. Repair or replace if necessary.
- 9.9 Check the surface of plastic and metal parts, e.g. slides, for damage and replace if necessary.

10 Quaterly Maintenance

- 10.1 Detailed inspection of the operation and stability of the equipment paying particular attention to any wear and tear.
- 10.2 Tighten all forms of attachment.
- 10.3 Repaint and retreat surfaces.
- 10.4 Maintenance of fall protection surfaces.
- 10.5 Check the height of the fall and top up with loose filler if necessary. If the posts are labelled, top up as far as the mark.
- 10.6 Retighten all bolts

11 Half Yearly Maintenance

- 11.1 Stability (check posts, bracing, foundations, etc.). Ascertaining whether there are any changes in equipment safety as a result of repairs that have been carried out or components that have been added or replaced.



Annual Maintenance

12 Annual Maintenance

- 12.1 Ascertaining that the equipment, foundations and surfaces are safe for operation.
- 12.2 In particular, the equipment should be checked for decay and corrosion. It may be necessary to dig out or excavate certain components in order to do so. Zinc paint should be applied to corroded areas and scratches.



The equipment must be inspected by someone **with the necessary expertise** in strict compliance with the instructions issued by the manufacturer.

A copy of the inspection record should be given to the operator, who must confirm receipt.

13 Maintenance Printout

Name of Item: Tower Carousel _____ / Art. No. 20.01.150 _____

Location: _____

Customer or Operator: _____
(Local Authority, School, etc.)

Date of inspection	Inspector	O.K.	Accessible	Barriered	Defects	Repaired by	Date

14 Hand Over Document



After the installation of the equipment pass the installation and maintenance documents to the operator. The operator has to receive the hand over documents. The complete filled and signed hand over document should be sent to the supplier.

Art.-No.: 20.01.150

Type of Item: Tower Carousel

Serial Number: _____

Customer or Operator (Local Authority, School, etc.):

Competent Person in Charge:

Installation Company (Address):

Responsible Assistant (Assembler):

Received the complete assembly instructions, maintenance instructions and maintenance printout

(Signature of Operator) (Signature of Installation Company)
(Stamp)

Date: _____