

A Assembly Instructions

Space Capsule, Art-No. 20.01.020



Revision history

Revision 0 – 2004-06-22

First approved version

Assembly instructions

Revision 3 – 2011-06-08

Nur noch 4 Befestigungsschrauben

VA-Rohr FH

All rights reserved.

© Copyright 2003 Spogg Sport-Güter GmbH

Contents

A	Assembly Instructions	1
1	Introduction Assembly	4
2	Datasheet	5
3	Delivery Contents (parts list with part numbers)	7
4	Erection Instructions	11
5	Post Installation Checks	19
B	Maintenance Instructions	21
6	Introduction Maintenance	23
7	General Maintenance Information	24
8	Specific Maintenance Advice	25
9	Maintenance Timetable	26
10	Monthly Maintenance	27
11	Quarterly Maintenance	27
12	Annual Maintenance	28
13	Maintenance Printout	31
14	Hand Over Document	33

List of Tables

Table 3.1: Delivery contents, in words	7
Table 3.2: Delivery contents, in symbols	9

1 Introduction Assembly

1.1 General Information

This equipment should be installed, inspected, maintained and operated in accordance with EN1176-7 guidelines.

Before installation work commences, please check that you have all of the equipment and fixation components in the parts list provided (see Tables 3.1 and 3.2).

Any spare parts that may be required can be obtained directly from your supplier.



Attention

Following installation, complete assembly instructions, maintenance instructions and a maintenance record must be sent to the operator who must confirm receipt in writing. See the last page of this document.



Attention

All nuts and bolts are hot-dip galvanised or stainless steel.

One of the characteristics of stainless steel is that uncontrolled cold welding may occur when the nuts are tightened. To prevent this, it is necessary to spray the nuts and bolts with Teflon spray or another similar lubricant.

We hereby confirm that this play equipment has been tested and certified in accordance with the play equipment standard EN 1176.

2 Datasheet

1. Space requirement: Ø3.50m and Ø 8.00m or Ø11.00m including safety zone, Height of fall 2.00 m

The given required safety area is bigger in dimension than required by the EN because of our experience. For carousels a safety area of +2m to the diameter of the item is required.

According to the EN 1176 this article needs a safety area of 8.00m - we recommend to take 11.00m here. But it is sufficient to provide the required fall protection material to the safety area.

Attention! You need a smooth transition without solid bordering/edging (rocks or similar) following to the safety area!

2. Required Safety Surface:

Surface material	Description mm	Minimum thickness of layer mm	Maximum height of fall mm
Topsoil grass			<= 1000*
Chipped bark	20 – 80 grain size	300/400	<= 2000/3000
Wood chippings	5 – 30 grain size	300/400	<= 2000/3000
Sand	0.2 – 2 grain size	300/400	<= 2000/3000
Gravel	2 – 8 grain size	300/400	<= 2000/3000
Other ground materials	As recommended by manufacturer		

3. Name and overall dimension of the largest component:
Steel post (1 item) length 3.80m, Ø 193 mm

4. Name and weight of the heaviest component:
Rotation element (1 item), 110 kg

5. Intended age group: 3 years and over

6. **Please note that this equipment is set in concrete.**

Concrete: C25/30

Foundations/area to be excavated:

1 x 1.20 m long x 1.20 m wide, total depth 1.10 m including 10 cm drainage

1 x 1.20 m long x 1.20 m wide x 0.80 deep

Top edge of concrete rounded



Attention! Round off edges of concrete foundations!

Important – All sizes of foundations are valid for soil class 3 – 4 (standard soil). In case of sandy and soft soil we strictly recommend to enlarge the foundation dimensions.

Soil class 4: soft to medium plasticity, interleave bound, with minor portion of stone (portion < 30% with bigger diameter of 63 mm grain size).

Soil class 5: ground with soil class 3 and 4 with big portion of stones (portion > 30% with bigger diameter of 63 mm grain size).

In case of sandy and soft soils, the surface measure of foundations have to be enlarged by about 50%!

7. Assembly time, once foundations complete: 2 -3 hours.
Required assistance: 2 - 3 people.
8. Any spare parts which may be required can be obtained directly from your supplier.
9. **We hereby confirm that this item of play equipment has been tested and certified in accordance with the play equipment standard EN 1176.**

3 Delivery Contents (parts list with part numbers)

3.1 In Words



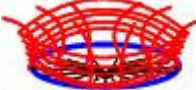



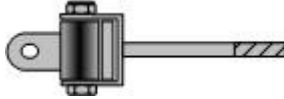
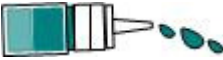







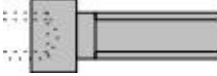
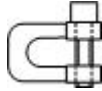

Table 3.1: Delivery Contents, in words







Pos.	Quantity	Element / Description	Size	O.K.	Missing
1	1	Steel post	3.80 m , Ø 193 mm		
2	4	Seesaw beam (cross bars)	1.65 m long		
3	1	Rope ring with netting			
4	1	Octagonal ring (2 parts)			
5	1	Rotating seesaw mechanism			
6	4	Red caps	f. Ø 14 cm		
7	1	Cover (shiny)			
100	4	Suspension support sleeve nut pre-assembled	M12		
101	3	Loctite			
102	6	Screw for Octagonal ring			
103	4	Hexagonal nuts (self-locking)	M10 DIN 985		
104	1	Cap nut	M16		
105	12	Wood screws	M5 x 30		
106	4	Thread bolt and 2 cover nuts	M10 x175 mm		
107	4	Allen screw	M10 x 30		
108	4	Schackle			
109	1	Ring nut (pre-assembled)	M16		
110	8	Caps (black)	f. M12		
111	4	Sleeve nut	M12		
112	16	Countersunk screw	M8 x 60 mm VA		
113	4	Self bearing screw	6.3 x 45 VA		
114	1	cover ring			
115	1	stainless steel tube	Ø 199 mm, 500 mm long		
116	4	Self bearing screw	5,5 x 25 VA		
	1	sidewalk flagstone			

Pos.	Quantity	Element / Description	Size	O.K.	Missing
		(by the customer)			

3.2 In Symbols

Table 3.2: Delivery Contents, in symbols

Pos.	Quantity	Symbol
1	1	 Steel post
2	4	 1.65 m long
3	1	
4	1	
5	1	
6	4	 f. Ø 14 cm
7	1	
100	4	 M12
101	3	
102	6	
103	4	 M10 DIN 985
104	1	 f. M16
105	12	 M16
106	8	 M10 x 175 mm   M10
107	4	 M10 x 30
108	4	
109	1	 M16
110	8	

Pos.	Quantity	Symbol
111	4	 <p>Sleeve nut M12</p>
112	16	 <p>M8 x 60 mm, VA</p>
113		 <p>6,3 x 45 mm VA</p>
114		 <p>cover ring</p>
115		 <p>stainless steel tube</p>
116	4	 <p>5,5 x 25 VA</p>
	1	 <p>sidewalk flagstone (by the customer)</p>

4 Erection Instructions

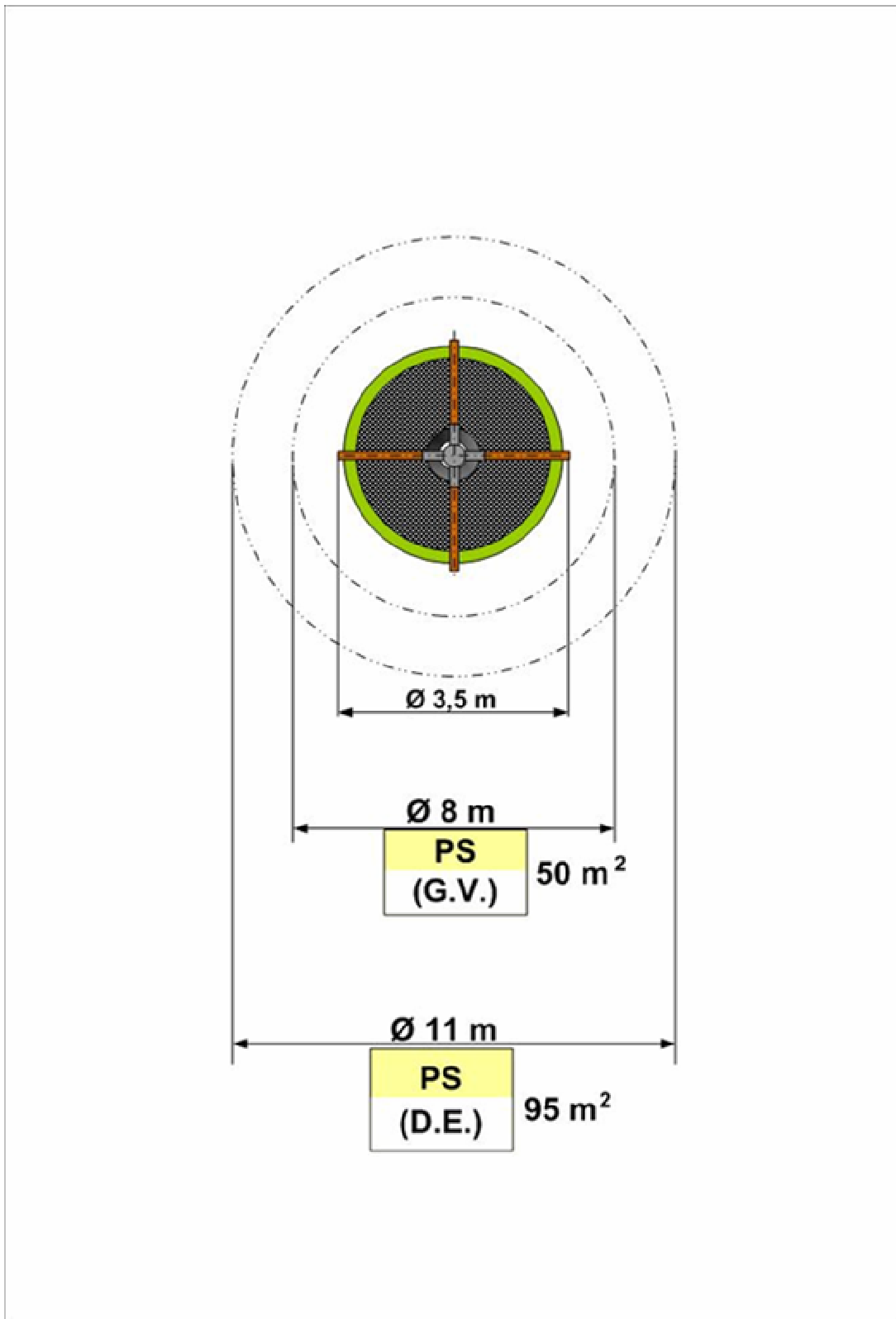

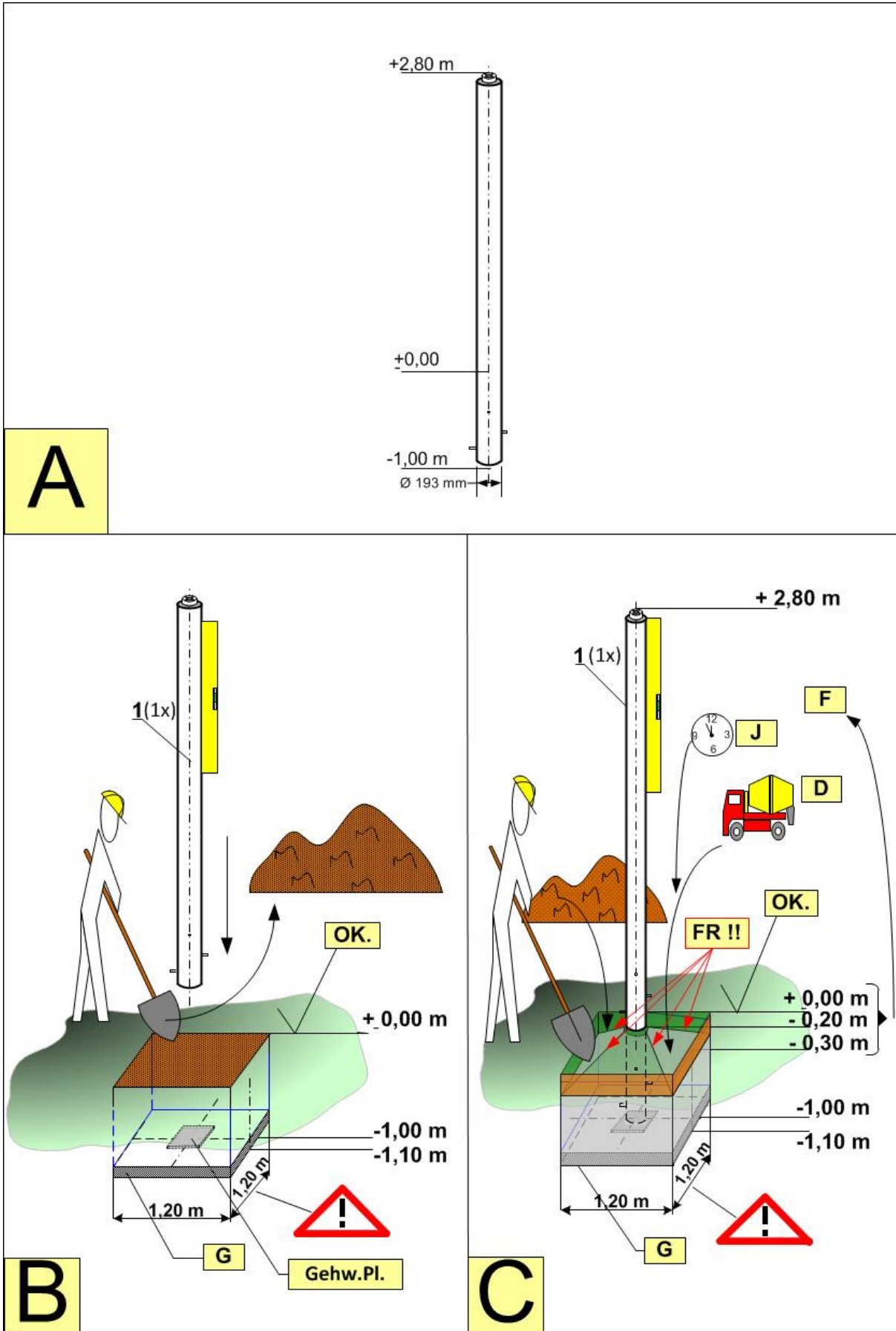

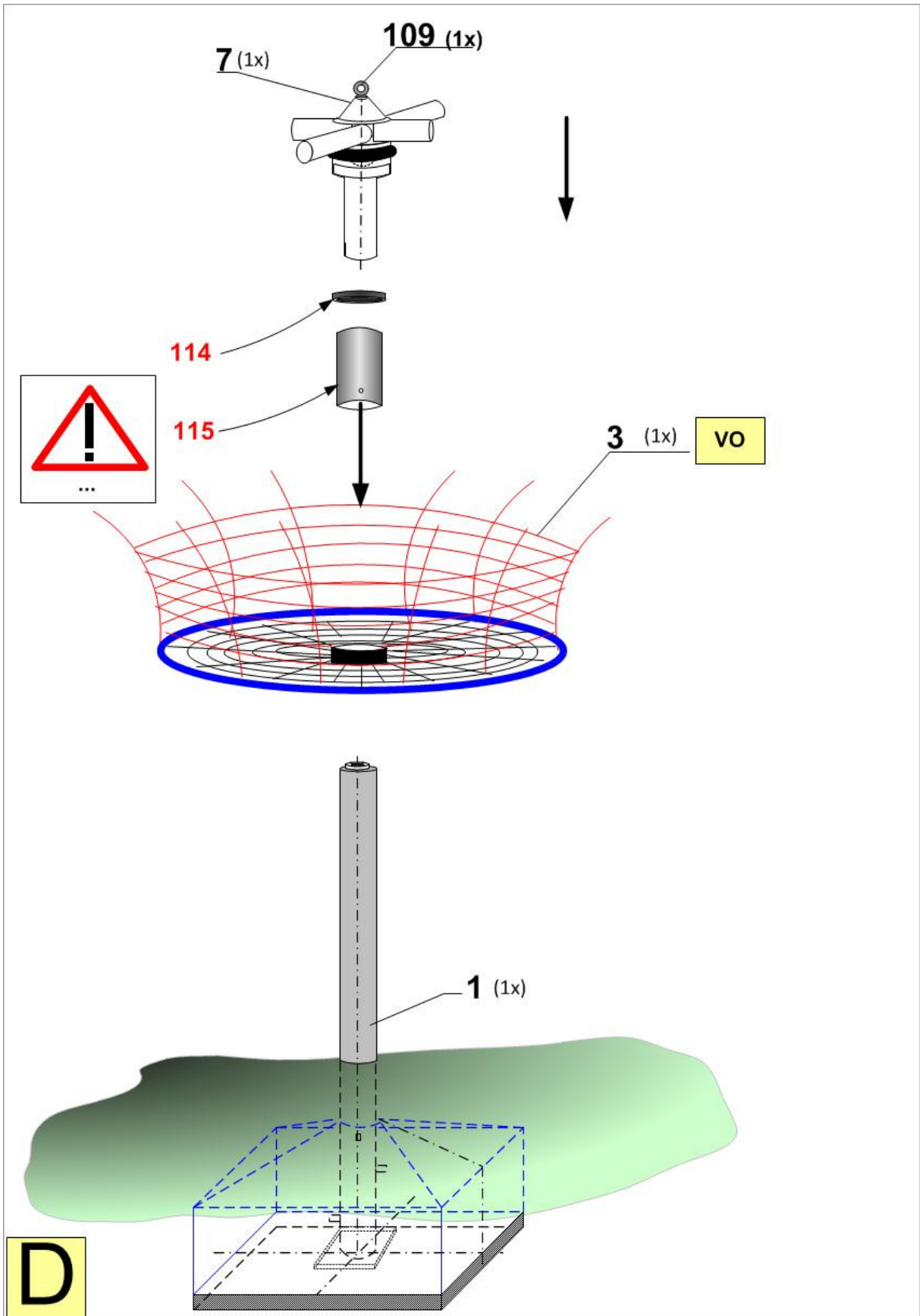

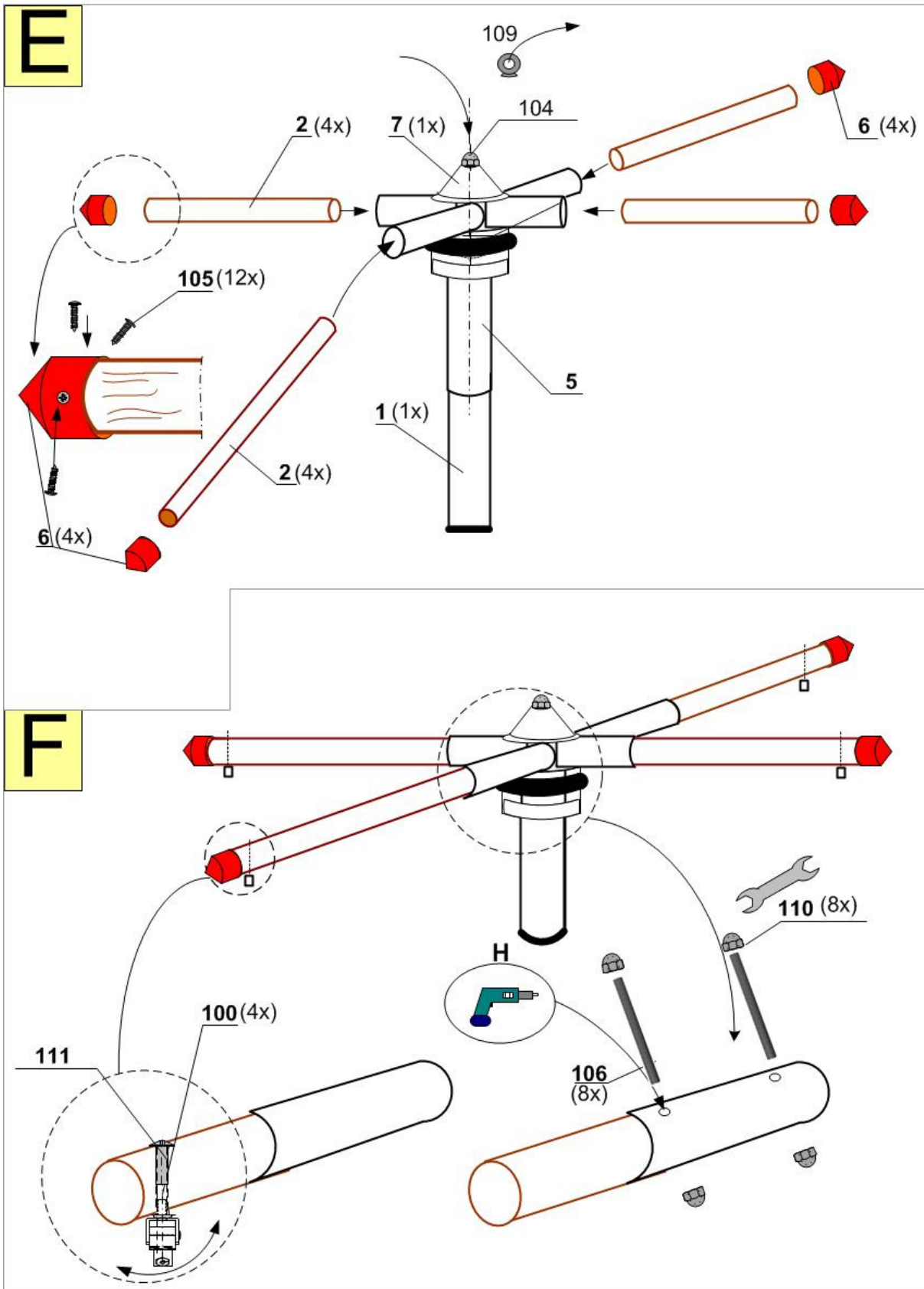

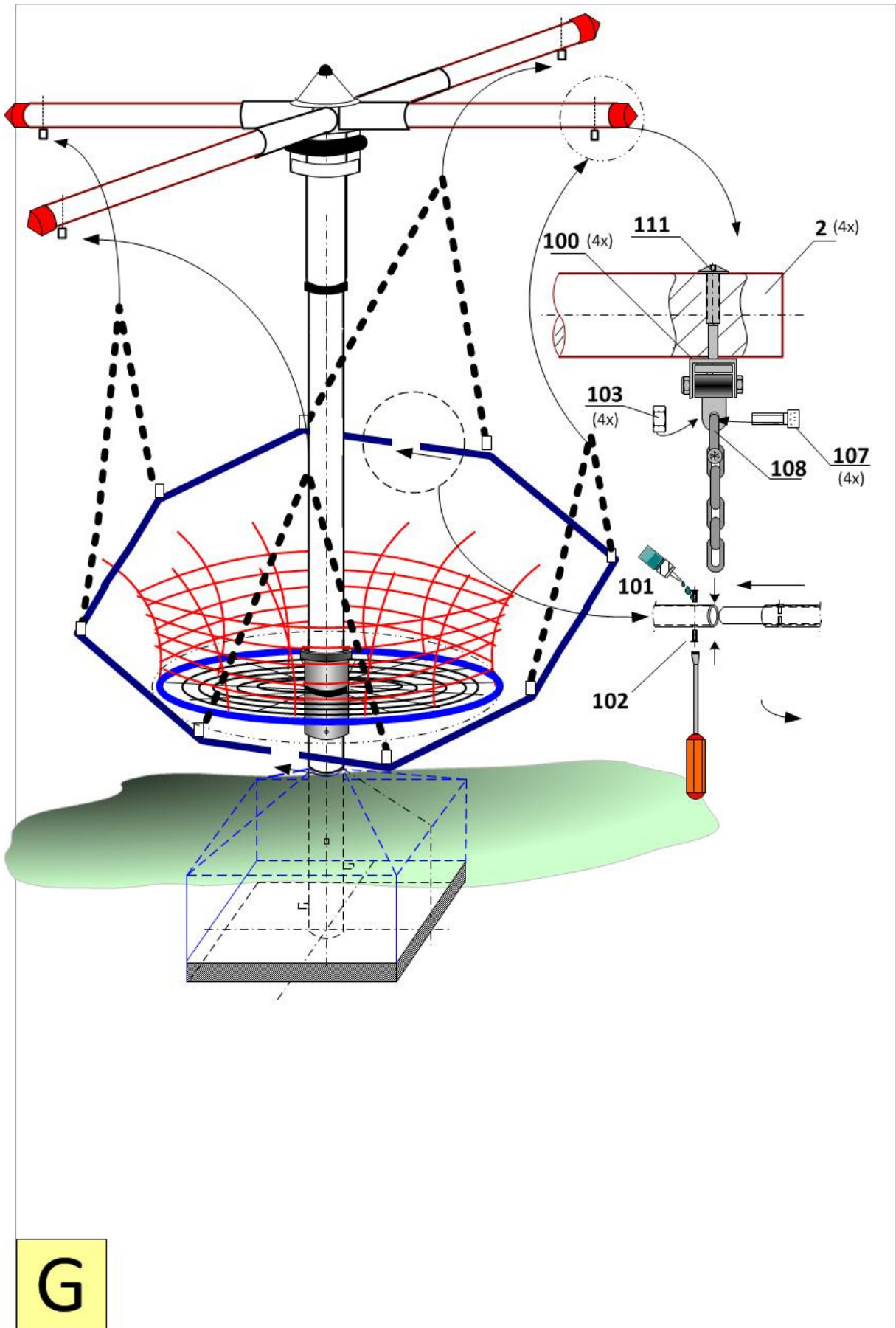

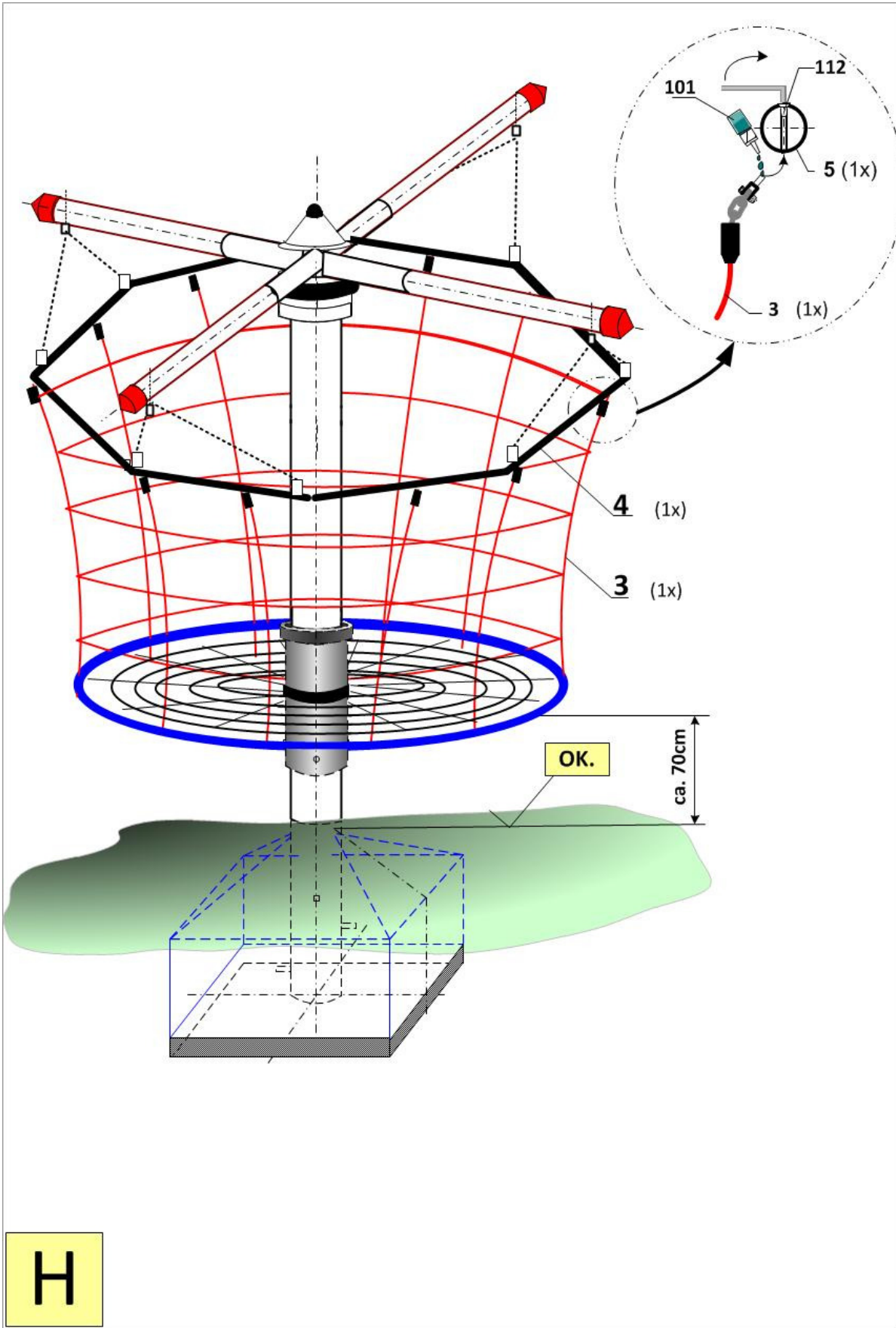

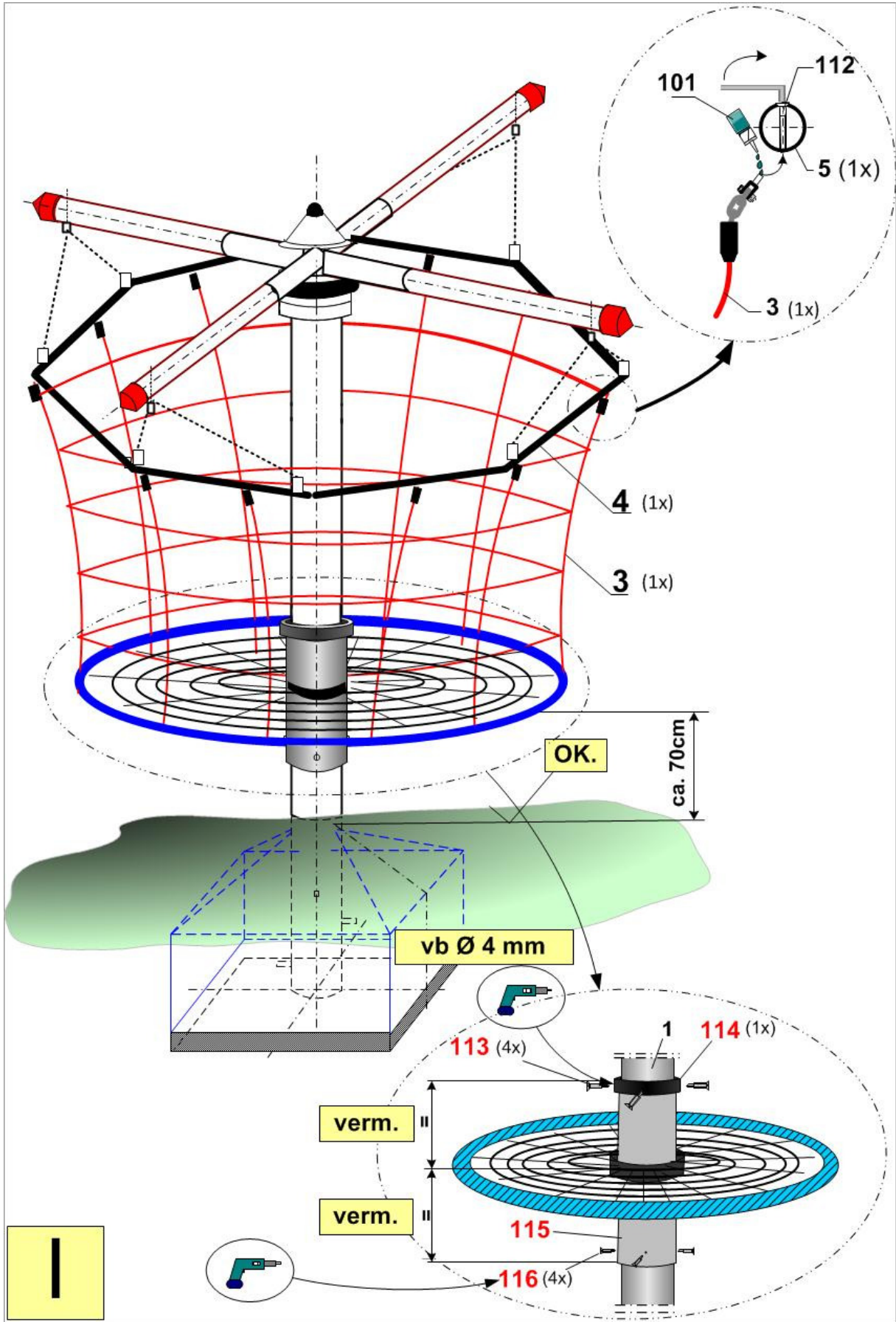



C	Fall protection material
D	Concrete quality C25/30
E	Upper edge of playing level
G	Drainage area
J	At least 7 - 8 days setting time
L	Safety area
	Round off edges of concrete foundations! Important – All sizes of foundations are valid for soil class 3 – 4 (standard soil). In case of sandy and soft soil we strictly recommend to enlarge the foundation dimensions.

See drawings

5 Post Installation Checks



If the equipment has not been installed safely, you must ensure that the public is prevented from using it.

5.1 Marking filler depth

- Labelling the posts to show the depth of material provided as fall protection (i.e. loose filler).

5.2 The equipment has not been installed safely in the following cases:

- Safe equipment installation is not complete.
- The protective surface has not been installed yet.
- Appropriate maintenance work cannot guarantee operational safety.

5.3 Removal of all assembly aids

- Please make sure that all assembly aids have been removed from the playing area. The equipment must not be approved for use until this check has been made.

5.4 Information about inspection of the equipment before it is used for the first time

- There are no special inspection requirements to be met before the equipment is used for the first time.

5.5 Retighten bolts

- After one week of play, please retighten all bolts again. Later upon respective maintenance.

B Maintenance Instructions

Space Capsule Art-No. 20.01.020



Revision history

Revision 0 – 2004-06-22

First approved version

Maintenance instructions

Revision 3 – 2011-06-08

Nur noch 4 Befestigungsschrauben

VA-Rohr FH

All rights reserved.

© Copyright 2003 Spogg Sport-Güter GmbH

6 Introduction Maintenance

6.1 General Information

This equipment should be installed, inspected, maintained and operated in accordance with EN 1176-7 guidelines.



Please note: Providing any necessary repairs are carried out, a piece of play equipment that is inspected regularly cannot become so damaged that it is dangerous.

Any spare parts which may be required can be obtained directly from your supplier.



This equipment should only be assembled, maintained and repaired by **persons with the necessary expertise**.
A copy of the inspection record should be given to the operator, who must confirm receipt.

**This maintenance instruction is based on the standard
“EN 1176-1:2008”.**

7 General Maintenance Information

7.1 Maintenance intervals

Maintenance intervals are based on average use. Please note that more frequent inspections and/or maintenance are required if the play equipment is subject to intensive use.

7.2 Inspection frequency

The frequency of inspections must be based on actual use. Factors that affect frequency include vandalism, location (e.g. coastal proximity), air pollution and the age of the equipment.

7.3 Maintenance products and procedures

All nuts and bolts are hot-dip galvanised or stainless steel. One of the characteristics of stainless steel is that uncontrolled cold welding may occur when the nuts are tightened. To prevent this, it is necessary to spray the nuts and bolts with Teflon spray or another similar lubricant.

7.4 Spare parts

All spare parts must conform to the manufacturer's specifications.

7.5 Identifying spare parts

All spare parts are listed in the parts list. The parts list follows the installation requirements.

7.6 Special instructions for the disposal of individual equipment components

No special instructions are necessary for the disposal of individual equipment components.

7.7 Special measures during the break-in period

No later than 2 weeks after assembly, all screwed connections should be checked and tightened if necessary.

7.8 Drainage holes

All drainage holes should be kept clear.

7.9 Maintenance of protective surfaces

Surfaces providing fall protection must also be maintained regularly. It is particularly important to maintain the correct level of loose surface material and add more if necessary.

7.10 Faults



Attention

Faults must be repaired as soon as they are detected. If serious defects that compromise safety cannot be repaired straight away, the public must be prevented from using the equipment with immediate effect.

7.11 Loose screws



Attention

Loose screws always cause quality problems and put safety at risk. Therefore, loose screws should always be tightened and checks carried out to ensure that there are no missing screws (e.g. look out for holes you can see through).

7.12 Preventing equipment use

Use of the equipment should be prevented in the event of incomplete installation, disassembly, maintenance, repairs and faults.

7.13 Safeguarding the guarantee

Steel posts and footings are guaranteed if regular maintenance is carried out and recorded in writing. Maintenance first takes place after 3 years. The steel posts must be excavated as far as the concrete foundations and checked for corrosion. Zinc paint should be applied to any corroded areas and scratches.

8 Specific Maintenance Advice

None

9 Maintenance Timetable

9.1 Special Advices

9.1.1 Maintenance interval

We strongly advise you to carry out inspections and maintenance work within the specified periods as use of the equipment, the weather and malicious vandalism cause wear and tear that compromises the safety and function of the equipment.

9.1.2 Maintenance intervals in the event of intensive use

Please note that more frequent inspections and/or maintenance are required if the play equipment is subject to intensive use.

9.1.3 Faults that compromise safety



In the event of a fault that compromises safety, quick action must be taken. This may involve repairing it immediately or shutting down and dismantling the equipment.

9.1.4 Faults that compromise function



Faults that compromise function should also be repaired immediately. Such faults lower the value of the equipment to the user and encourage malicious vandalism, which may render the equipment less safe. Any damage should also be repaired immediately.

10 Monthly Maintenance

- Check the spaces between the equipment and the ground (clearance and height of fall).
- Check the ground surface in the area with fall protection for hard objects and loose foundations.
- Check all connecting elements and fittings for wear and tear and tighten if necessary. Replace damaged or missing parts.
- Check that moving metal parts (joints, springs, etc.) move smoothly and are not worn. Replace if necessary. It is not necessary to lubricate joints as we only use maintenance-free metal roller bearings.
- Check all attachments such as chains, ropes, nets, etc. for damage and replace if necessary.
- Check rubber parts, sleeves, etc. for wear and tear or damage and replace if necessary.
- If necessary, remove excess padding material from the post footings due to danger of rotting.
- Check the surface of wooden parts for damage caused by the weather or external influences and mould. Repair or replace if necessary.
- Check the surface of plastic and metal parts, e.g. slides, for damage and replace if necessary.

11 Quaterly Maintenance

- Detailed inspection of the operation and stability of the equipment paying particular attention to any wear and tear.
- Tighten all forms of attachment.
- Repaint and retreat surfaces.
- Maintenance of fall protection surfaces.
- Lubrication of joints.
- Check the height of the fall and top up with loose filler if necessary. If the posts are labelled, top up as far as the mark.
- Retighten all bolts

12 Semi Annual Maintenance

- Stability (check posts, bracing, foundations, etc.).
- Ascertaining whether there are any changes in equipment safety as a result of repairs that have been carried out or components that have been added or replaced.



Annual Maintenance

13 Annual Maintenance

- Ascertaining that the equipment, foundations and surfaces are safe for operation.
- In particular, the equipment should be checked for decay and corrosion. It may be necessary to dig out or excavate certain components in order to do so. Zinc paint should be applied to corroded areas and scratches.



The equipment must be inspected by someone **with the necessary expertise** in strict compliance with the instructions issued by the manufacturer.

A copy of the inspection record should be given to the operator, who must confirm receipt.

Regular Maintenance (Image)

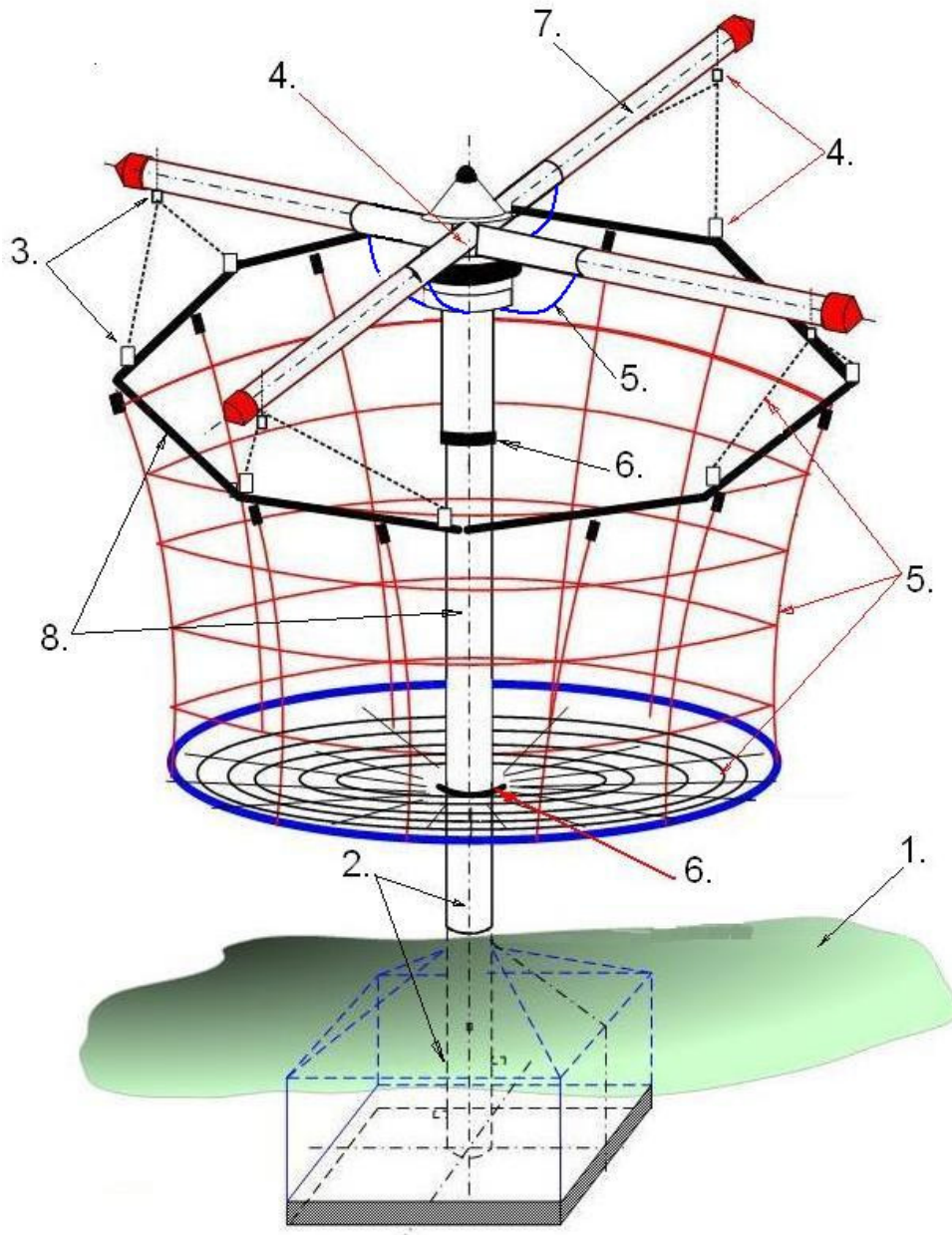

	W = weekly	m = monthly	y = yearly	w	m	1/4y	1/2y
1. proof surface area underneath the item for dangerous objects				<input checked="" type="checkbox"/>	<input type="checkbox"/>	<input type="checkbox"/>	<input type="checkbox"/>
2. proof stableness of standpole, bracing, foundation				<input type="checkbox"/>	<input type="checkbox"/>	<input type="checkbox"/>	<input checked="" type="checkbox"/>
3. proof wastage and tightness of fixations. Retighten or replace damaged items if necessary				<input checked="" type="checkbox"/>	<input type="checkbox"/>	<input type="checkbox"/>	<input type="checkbox"/>
4. proof moving parts (joints, springs, etc.) for wastage and function - replace if necessary. Greasing of joints is not necessary - only maintenance-free ball-bearings are used.				<input type="checkbox"/>	<input checked="" type="checkbox"/>	<input type="checkbox"/>	<input type="checkbox"/>
5. proof all added items (chains, ropes, nets, etc.) for wastage or damage - replace if necessary				<input checked="" type="checkbox"/>	<input type="checkbox"/>	<input type="checkbox"/>	<input type="checkbox"/>
6. proof all rubber items, sleeves, etc. for wastage and damage - replace if necessary.				<input checked="" type="checkbox"/>	<input type="checkbox"/>	<input type="checkbox"/>	<input type="checkbox"/>
7. proof surface of wooden parts for wastage and damage - replace if necessary				<input type="checkbox"/>	<input type="checkbox"/>	<input checked="" type="checkbox"/>	<input type="checkbox"/>
8. proof surface of plastic and metal parts (slides etc.) for wastage and damage - replace if necessary				<input checked="" type="checkbox"/>	<input type="checkbox"/>	<input type="checkbox"/>	<input type="checkbox"/>

We recommend to carry out the checkup and maintenance operation according to our guidelines, because high strain, atmospheric influence or vandalism can cause the loss of safety and function.

In case of a damage, which affects the safety, the playground item has to be blocked or disassembled and repaired immediately.

Damage, which affects the function, can cause the loss of safety, decrease the fun for playing and excite to vandalism. In this case the item has also to be repaired immediately.

Any kind of repair and maintenance has to be done by a competent person.

General remarks:

a regularly checked playground item couldn't be dangerous, because it can not be damaged like a unchecked item.

But the requirement is the replacement of the damaged parts from the checked playground item.

14 Maintenance Printout

Name of Item: Space Capsule _____ / Art. No. 20.01.020 _____

Location: _____

Customer or Operator: _____
(Local Authority, School, etc.)

Date of inspection	Inspector	O.K.	Accessible	Barriered	Defects	Repaired by	Date

15 Hand Over Document



After the installation of the equipment pass the installation and maintenance documents to the operator. The operator has to receive the hand over documents. The complete filled and signed hand over document should be sent to the supplier.

Art.-No.: 20.01.020

Type of Item: Space Capsule

Serial Number: _____

Customer or Operator (Local Authority, School, etc.):

Competent Person in Charge:

Installation Company (Address):

Responsible Assistant (Assembler):

Received the complete assembly instructions, maintenance instructions and maintenance printout

(Signature of Operator) (Signature of Installation Company)
(Stamp)

Date: _____